

# Predicting the Hysteretic Cycles of 3D-Reinforced Concrete Frames by ANN

Fatih BAHADIR, Fatih Süleyman BALIK

**Abstract**—In this study, artificial neural network (ANN) method is used to predict displacement data of 3D-reinforced concrete frames and compared with the experimental results of a testing series. Three reinforced concrete frames were produced two storey and 3D in 1/6 geometric scales which contained the deficiencies commonly observed problems in residential buildings in Turkey were tested under reverse-cyclic lateral loading as well as constant vertical loading until failure. These experimental studies are 3-D and having different window opening in brick wall. This study is concerned with the problem of estimation of displacement data when the LVDT of 103 numbers are corrupted and some data of hysteretic cycles are missed. As a result, the values are very closer to the experimental results obtained from training and testing for artificial neural networks model. RMSE,  $R^2$  and MAE statistical values that calculated for comparing experimental results with artificial neural networks model results have shown this situation.

**Keywords**—3D-Reinforced Concrete, ANN, Hysteretic Cycles, Displacement

## I. Introduction

The linear variable differential transformer (LVDT), dial gauge, load cell, strain gauge and accelerometer are widely used in civil engineering for the measurement of parameters such as displacement, strain, load, acceleration and angles. These instruments are mostly used in the experimental study to structural behavior or measure material properties. In the experimental study used measurement instruments mostly based on the electrical or magnetic principles. They have also been used in experimental research as tools to provide accurate and stable measurements in the laboratory, but measurement instruments always may not work correctly. For example;

- Low signal loss of measurement instrument
- Measuring instruments are not working due to power cuts
- Electromagnetic noises
- Calibration problems of measurement instruments
- During experimental study, measurement instruments have been damaged
- e.g.

These instruments always are used at experimental studies and these always are facing risk. Risk factors and risk management options may differ for experimental studies. The missing and not correct measurements are caused by variety of reason. If some measurements aren't available to find or not correct, they are predicted by considering other measurements.

To different displacement data and loads of experimental studies using neural network model proposed in this study, the

experimental data from the experimental studies were adopted to predict the unavailable displacement data. These experimental studies are 3-D and having different window opening in brick wall. This study is concerned with the problem of estimation of displacement data when the LVDT of 103 numbers are corrupted and some data of hysteretic cycles are missed.

## II. Experimental Program

### A. Properties of the Test Specimens

In this study, three reinforced concrete frames were produced two storey and 3D in 1/6 geometric scales which contained the deficiencies commonly observed problems in residential buildings in Turkey were tested under reverse-cyclic lateral loading as well as constant vertical loading until failure. The experiments were manufactured and tested in the Structural Testing Laboratory at the Necmettin Erbakan University –Konya-TURKEY (Fig 1). In all test specimens, the geometric dimensions, concrete qualities and reinforcement forms of the frames were same (Fig 2). In order to achieve a nonductile RC frame, test frames were constructed deliberately with some deficiencies commonly observed in residential buildings, in Turkey, to reflect several seismic deficiencies [1]. Test frames were detailed and constructed deliberately with some deficiencies; low strength concrete, strong beam-weak column formation, wide spacing of beam and column stirrups, no column stirrups at the beam-column joints, no confinement zones at the end of the columns and beams. The stirrups were prepared 90° hooks and that stirrups placed to free ends of columns and beams of the test specimens.

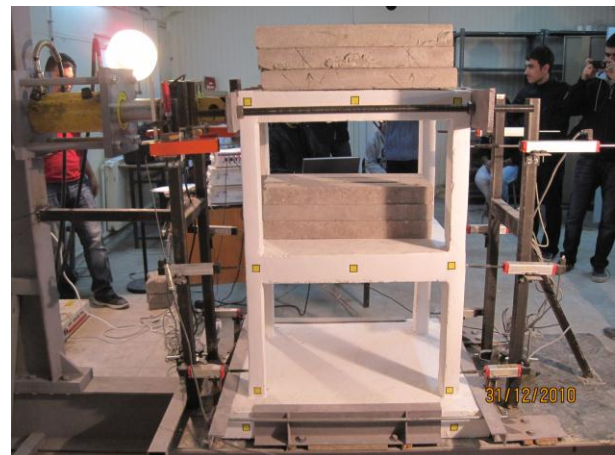

Fig 1. General photo of the test setup for the experimental study.

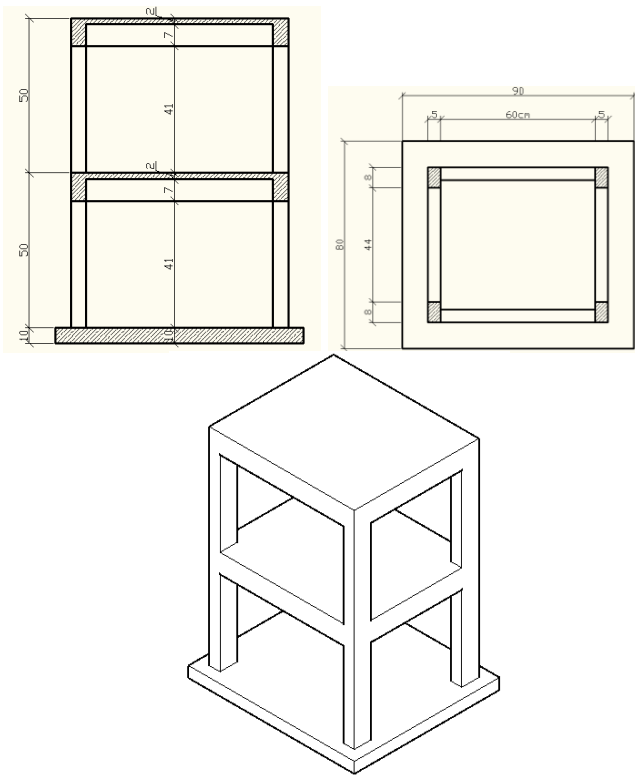

Fig 2. Dimensional of the generic specimen (bare specimen)

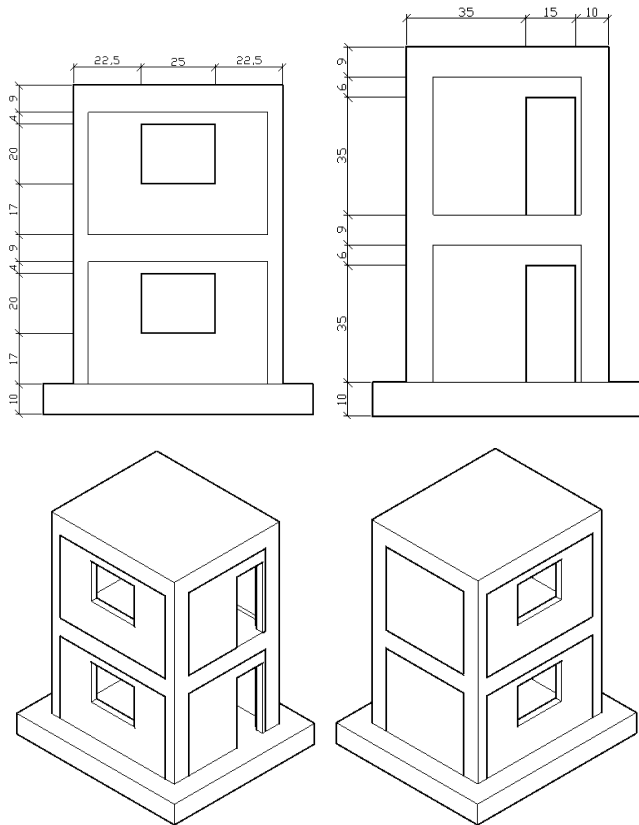
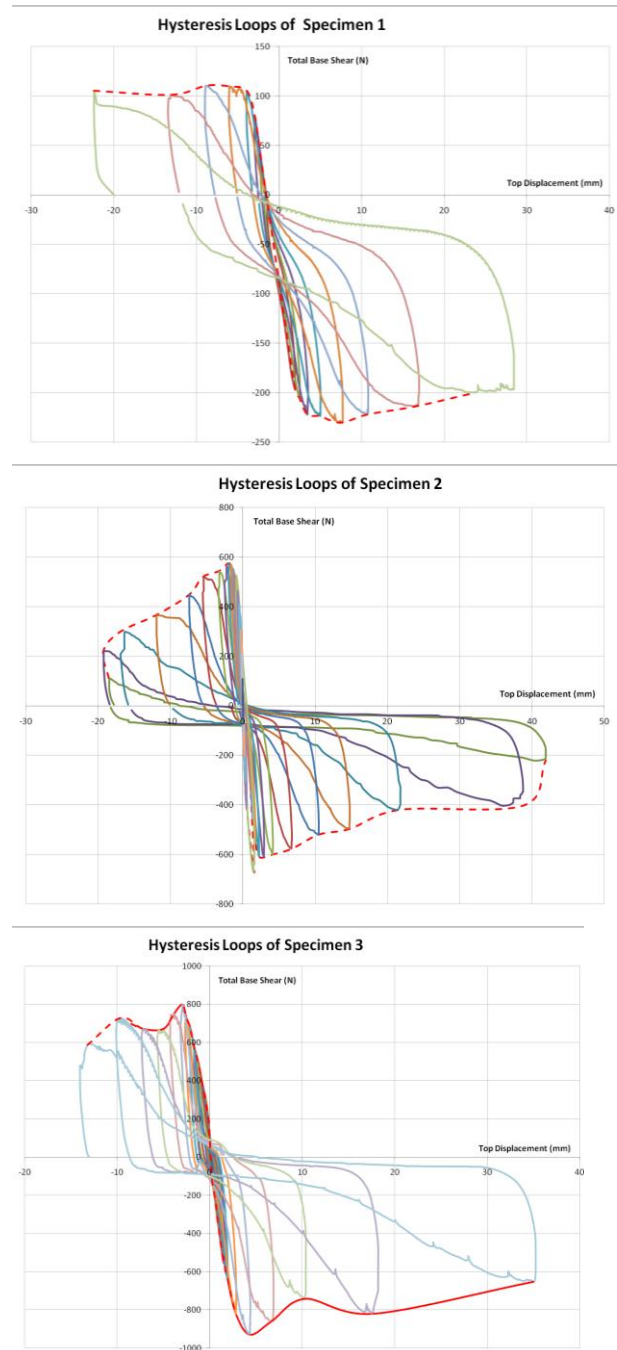

Fig 3. Dimensional of the Specimen 2(window opening)

## B. Test Results

Base shear versus top displacement hysteresis curves and envelopes are represented in Fig 4 for all specimens.



Graphics are not in the same scale

Fig. 4. Base shear versus top displacement hysteresis curves and envelopes of all specimens

In generally, the specimens of brick walls (Specimen 2 and Specimen 3) were occurred intensive the diagonal shear cracks at the end of test. Failure mode of the Specimen 1(no brick wall) was occurred the shear cracks and bending cracks of frame. The crack patterns of Specimen 1 (reference specimen),

Specimen 2 (window opening) and Specimen 3 (no window opening) at the end of the test as it can be seen in Fig. 5.

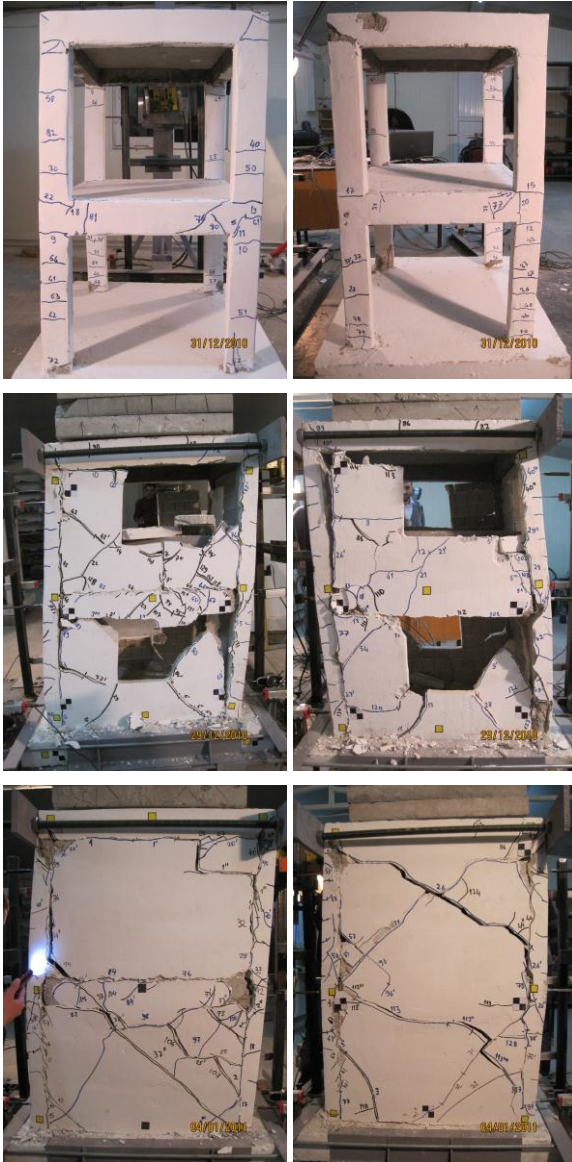

Fig 5. Specimen 1 (reference specimen), Specimen 2 (window opening) and Specimen 3 (no window opening) can be seen at the end of the test, respectively.

### III. Neural Network Model Structure and Parameters

In this study, a multilayer perception (MLP) algorithm was adopted. Multilayer perceptions (MLPs) are feed-forward neural networks trained with the standard back propagation algorithm. Feed-forward neural networks are composed of layers of neurons, in which the output of each layer of neurons is connected to the input of the next layer [2]. Most neural network applications involve multilayer perceptions (MLPs).

ANN model is carried out in this research has four neurons in the input layer and one neurons in the output layer as demonstrated in Fig. 6.

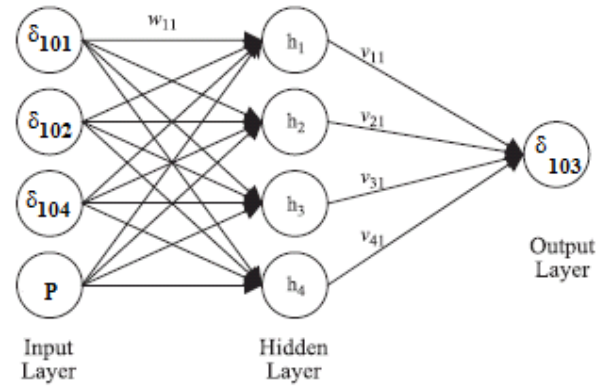

Fig 6. The system used in the ANN model

In training and testing of the neural network model load (P), displacement data of 101 No. LVDT ( $\delta_{101}$ ), 102 No. LVDT ( $\delta_{102}$ ) and 104 No. LVDT ( $\delta_{104}$ ) were entered as input; while 103 No. LVDT ( $\delta_{103}$ ) values of different loads were used as output. A multilayer perception (MLP) developed in this research has four neurons in the input layer and one neuron in the output layer as demonstrated in Fig. 7. One hidden layer was used in the architecture of multilayer perceptrons (MLP) due to its minimum absolute percentage error values for training and testing sets [2,3]. In the hidden layer four neurons were determined. The neurons of neighboring layers were fully interconnected by weights. Momentum rate and learning rate values were determined and the model was trained through iterations. The trained model was tested only with the input values and the predicted results were close to the experimental results [2,3]. The values of parameters used in this research are as follows:

- Number of input layer units=4
- Number of hidden layer=1
- Number of hidden layer neurons=4
- Number of output layer neuron=1
- Momentum rate= 0.1
- Learning rate=0,7
- Error after learning=0,001
- Learning cycle=6000

In ANN1 model, the prediction of the trained neural networks in one by one cycle satisfies the required desirable output results, except for the last cycle. In ANN2 model, the prediction of the trained neural networks in two by two cycles satisfies the required desirable output results, except for the last cycles. Moreover, in ANN3 model, the prediction of the trained neural networks in threes cycles satisfies the required desirable output results, except for the last cycles. And these output results compared experimental studies.

Activation function is a function that processes the net input obtained from sum function and determines the cell output [3, 4]. In almost all cycles of ANN1, ANN2 and ANN3 models were used linear axon function as activation function. But the last cycles of ANN1, ANN2 and ANN3 models were

used tanh axon function are as the activation function. The output of the neuron is individually calculated employing Eq.1 and Eq.2 with activation functions as follows [18]:

$$(out)_j = f(net)_j = \dots \quad \text{Linear (1)}$$

$$(out)_j = f(net)_j = \tanh \dots \quad \text{Tanh (2)}$$

This function calculates the net input that comes to a cell [14-15]. The weighted sums of the input components are calculated by using Eq. 3 as follows:

$$(net)_i \quad (3)$$

#### IV. Results and Discussion

In this study, the error arose during the training and testing in ANN can be expressed as a root-mean-squared error (RMSE) and is calculated [2,3] using Eq.4.

$$RMSE = \sqrt{\frac{1}{n} \sum_{i=1}^n (t_i - o_i)^2} \quad (4)$$

Besides, the absolute fraction of variance ( $R^2$ ), and mean absolute error MAE are computed utilizing Eqs.5 and Eq. 6, respectively [2,3].

$$R^2 = 1 - \left( \frac{\sum_{i=1}^n (t_i - o_i)^2}{\sum_{i=1}^n (o_i)^2} \right) \quad (5)$$

$$MAE = \frac{1}{n} [\sum_{i=1}^n |t_i - o_i|] \quad (6)$$

Where  $t$  is the target value,  $o$  is the output value;  $n$  is the number of exemplars in the data set [5].

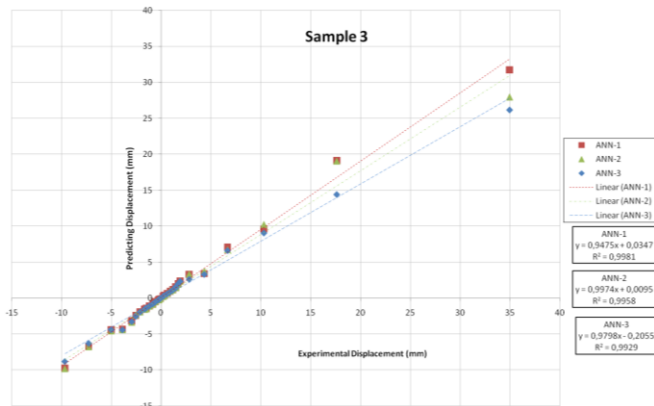

Fig.8. Comparison of displacement ( $\delta$ ) envelope curve of experimental results of Sample 3 with the testing results of ANN.

The statistical values for  $\delta$  values obtained from testing in ANN model as RMSE,  $R^2$ , and MAE are also given Table 1. The  $\delta$  values obtained from testing in ANN models and experiments can be seen for Sample 3 in Fig.9. The  $\delta$  values obtained from testing in ANN model experimental studies of Sample 2 can be seen in Fig.9. As it can be seen in Fig.9 the values reached from ANN are very closer to the experimental

results. When the values reached from testing in ANN model in terms of statistical values evaluated, all the values are very closer to the experimental results.

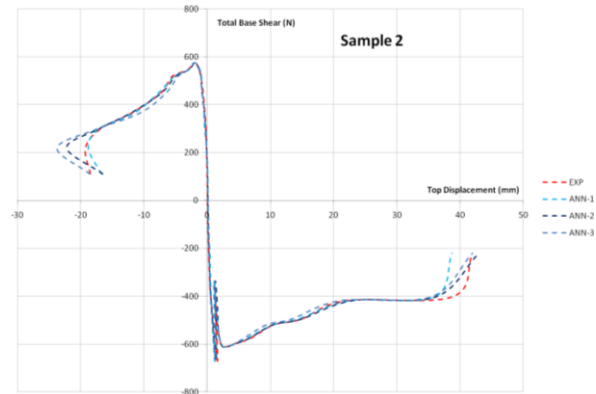

Fig.9. Comparison of predicted and envelope curve of experimental study of Sample 2.

**Table 1.** The displacement data ( $\delta$ ) statistical values of proposed ANN

Statistical Parameters	Sample 1		
	ANN1	ANN2	ANN3
	Testing set	Testing set	Testing set
RMSE	0,029	0,073	0,0888
MAE	0,127	0,203	0,215
$R^2$	0,999	0,999	0,998
Sample 2			
RMSE	0,696	0,544	0,355
MAE	0,372	0,349	0,332
$R^2$	0,992	0,995	0,995
Sample 3			
RMSE	0,341	1,082	2,171
MAE	0,306	0,401	0,543
$R^2$	0,996	0,995	0,998

#### V. CONCLUSIONS

In order to predict the displacement data under vertical load, we used different load and displacement data of stories. This study includes the manipulation of tested samples at the laboratory to train and to validate the artificial neural networks [6]. In the models constructed in ANN methods, multilayer perception was used respectively. The model was trained with input and output data. The values are very closer to the experimental results obtained from testing for artificial neural networks model. RMSE,  $R^2$  and MAE statistical values that calculated for comparing experimental results with artificial neural networks model results have shown this situation [2,3].

As a result, the unavailable displacement data can be predicted in the models in artificial neural networks without attempting any experiments in a quite short period of time with tiny error rates. The obtained conclusions have shown that artificial neural networks for predicting displacement data.

Fatih BAHADIR  
Necmettin Erbakan University, School of Higher Education Civil Program  
Konya,TURKEY

Fatih Süleyman BALIK  
Necmettin Erbakan University, School of Higher Education Civil Program  
Konya,TURKEY

## References

- [1] S. Altın, Ö. Anıl, M.E. Kara, M. Kaya, “An experimental study on strengthening of masonry infilled RC frames using diagonal CFRP strips,” Composites Part B: Engineering, vol 39, issue 4, pp. 680-693, June 2008.
- [2] İ.B. Topçu, C. Karakurt, M. Sarıdemir, “Predicting the strength development of cements produced with different pozzolans by neural network and fuzzy logic,” Materials and Design, vol.29, issue 10, pp 1986-1991, December 2008.
- [3] M. Kamanlı, M. Y. Kaltakçı, F. Bahadır, F.S. Balık, H. H. Korkmaz, M. S. Döndüren, M. T. Çöğürçü,” Indian Journal of Engineering & Materials Sciences, vol.19, pp. 87-94, April 2012.
- [4] İ.B. Topçu, M. Sarıdemir, “Prediction of compressive strength of concrete containing fly ash using artificial neural networks and fuzzy logic”, Computational Materials Science, vol.41, issue 3, pp. 305-311, January 2008.
- [5] H. Xie, L. Liu, F. Ma, “Performance Estimation of Cooling Towers Using Adaptive Neuro-Fuzzy Inference”, Natural Computation, 2008. ICNC '08. Fourth International Conference, vol 7, pp. 250-254, October 2008.
- [6] M.M. Alshihri, A. M. Azmyb, M. S. El-Bisya, “Neural networks for predicting compressive strength of structural light weight concrete”, Construction and Building Materials, vol 23, issue 6, pp. 2214-2219, June 2009,

About Author (s):

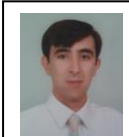

Asisst. Prof . Dr. in the School of Higher  
Education Civil Program  
Department at Necmettin Erbakan  
University.