

# An Improved Intelligent Temperature Measurement by RTD using Optimal ANN

Santhosh K V

Dept of Electrical Engineering  
National Institute of Technology, Silchar, India

B K Roy

Dept of Electrical Engineering  
National Institute of Technology, Silchar, India

**Abstract**— This paper aims at designing an intelligent temperature measuring technique by Resistance Temperature Detector (RTD) using optimal Artificial Neural Network (ANN). The objectives of the present work is (i) to extend the linearity range of RTD and (ii) to provide intelligence in the measuring technique so as to measure the temperature under variation (within a pre-specified range) of temperature co-efficient parameters  $R_0$ ,  $a$ ,  $b$  and  $c$ , but without any change in calibration circuit. (iii) To achieve the objective (i) and (ii) by an optimal ANN. An optimal ANN is considered based on minimum mean square error (MSE) and Regression by comparing various scheme and algorithm. The proposed technique provides linear relationship of the overall system over a wider range and makes it independent of temperature co-efficient. Since, the proposed intelligent temperature measuring scheme produces output independent of physical properties of RTD, it avoids the requirement of repeated calibration every time the RTD is replaced.

**Keywords**—Artificial Neural Network, Resistance Temperature Detector, Linearization, Sensor Modeling

## I. Introduction

Temperature is one of the basic quantities of any physical system in addition to mass, length, time and electric current. Temperature is that physical property of a system that qualitatively/ quantitatively expresses the common notions of it being hot or cold. Temperature is one of the most frequently used process measurements. Almost all chemical processes and reactions are temperature dependent. There are many areas of industry in which temperature measurement is essential. Such applications include steam raising and electricity generation, plastics manufacture and moulding, milk and dairy products, and many other areas of the food industries. Thus, an accurate and precise measurement of temperature is very important.

Many methods have been developed for measuring temperature. Most of these rely on measuring some physical property of a working material that varies with temperature. RTD is one such sensor which finds a wide application in a process industry because of its characteristics like accuracy and precision. However in the RTD the problem of non linearity has restricted its applications. To solve the problem

of linearizing a sensor, there are in general two methods, the first one requires nonlinear analog circuit and the second uses numerical methods that are computed by microprocessor or personal computer [1]. The first method has a few practical drawbacks. Further, the whole circuitry may be altered or replaced when there is need to change RTD to achieve wide range, different sensitivity, cost etc. This increases the time and effective cost of the instrument. The last method is preferred because computer is used today for data acquisition and also it has the advantage of linearization on taking into account the effect of disturbing variables

Artificial neural networks are broadly useful in a wide range of applications such as signal and image processing, pattern recognition [2], control systems [3] and recently instrumentation [4]. Because of their nonlinear characteristics, they are very useful in solving complex problems more accurately than linear techniques. So a method has been proposed in this paper using the concept of ANN. The ANN model is added in cascade to a data conversion circuit which will be trained to produce the linear relation between the input temperature and output of ANN. Further it's also made intelligent so as to produce results independent of physical parameters of the RTD so that no action is to be taken even though there is a change in RTD.

Literary survey done suggests in [5] and [6], linearization of RTD is done using computer written programming. In [7] linearization of RTD using circuits has been discussed. In [8], linearization of RTD using neural network algorithm is discussed. In [9] linearization using circuits is discussed. In [10], linearization using PIC microcontroller is discussed. In [11], linearization of RTD and making it independent of parameters is discussed. In [12], linearization of thermistor and making it independent of parameter is discussed.

The paper is organised as follows: after introduction in Section-I, a brief description on RTD is given in Section-II. The output of RTD is resistance; a brief discussion on data conversion unit i.e. an amplifier is discussed in Section-III. Section-IV deals with the problem statement followed by proposed solution in Section-V. Finally, result and conclusion is given in Section-VI

## II. RESISTANCE TEMPERATURE DETECTOR

Resistance thermometers, also called resistance temperature detectors or resistive thermal devices (RTDs), are temperature sensors that exploit the predictable change in electrical resistance of some materials with change in temperature.

The relation between temperature and resistance is given by the Callendar-Van Dusen equation [11], [13], [14] as shown in eqn (1) and eqn (2)

$$R_T = R_0 (1 + aT + bT^2 + c(T-100)^3) \quad (1)$$

for  $-200^\circ\text{C} < T < 0^\circ\text{C}$

$$R_T = R_0 (1 + aT + bT^2) \quad (2)$$

for  $0^\circ\text{C} < T < 650^\circ\text{C}$

where

$R_T$  – resistance at temperature  $T^\circ\text{C}$

$R_0$  – resistance at temperature  $0^\circ\text{C}$  (reference resistance)

a, b and c are constants

## III. DATA CONVERSION CIRCUIT

The block diagram representation of the proposed technique is given in Fig 1

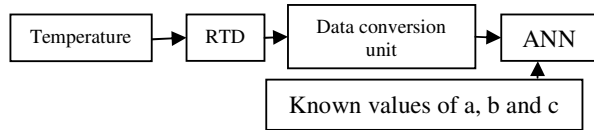

Fig 1: Block diagram of the proposed measuring technique

The resistance variation of the RTD can be measured by a bridge, or directly by volt-ampere method. But the major constraint is the contribution of the lead wires in the overall resistance measured. Since the length of lead wire may vary, this may leads to a false reading in the temperature to be measured. There must be some method for compensation so that the effect of lead wires in resistance measurement is eliminated. This can be achieved by using three wires RTD shown in Fig. 2 [15], [16]. The sensor is excited by a constant current source  $I_0$  through its lead-2 while lead-1 is connected to the ground point of the measurement circuit. Lead-2 of the sensor is also connected to the input of the amplifier  $A_1$  whose gain is set to 1 and lead-3 is connected to the input  $A_2$  whose gain is 2. The outputs  $V_1$  and  $V_2$  of the amplifiers  $A_1$  and  $A_2$  respectively are given by

$$V_1 = I_0(R_T + 2R_1) \quad (3)$$

$$V_2 = 2.I_0(R_T + R_1) \quad (4)$$

Differential amplifier  $A_3$  gives the difference between these two signals  $V_2$  and  $V_1$  to produce an output  $V_0 = I_0R_T$ , which is dependent only on the sensor resistance. It may be noted

that in earlier methods, compensation was sought by taking the ratio of two unequal resistances. The additional resistance of one lead wire was added to both the resistances. Such an arrangement could not always produce perfect compensation. In our method, on the other hand, the additional voltages developed across the lead resistances are totally canceled out by subtraction. Thus perfect compensation is achieved irrespective of the sensor resistance value.

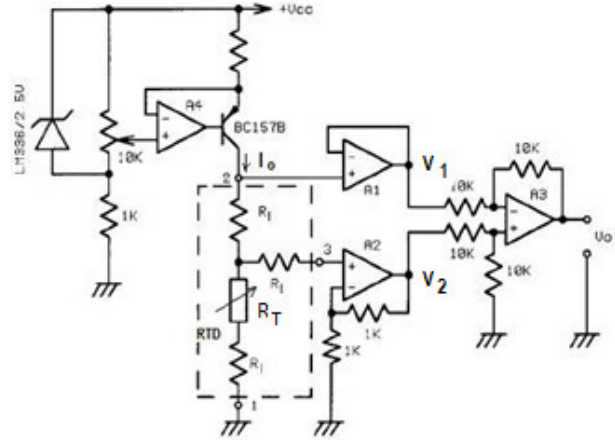

Fig. 2: Data converter unit with RTD

## IV. Problem statement

In this section, characteristic of RTD is simulated to understand the difficulties associated with the available measuring scheme. For this purpose, simulation is carried out with three different values of  $R_0$  these are  $R_0 = 100, 300$  and  $500$ . Three different values of  $a = 2 \times 10^{-3}, 4 \times 10^{-3}$  and  $6 \times 10^{-3}$ . Three different values of  $b = -5 \times 10^{-7}, -6 \times 10^{-7}$  and  $-7 \times 10^{-7}$ . Three different values of  $c = -2 \times 10^{-12}, -4 \times 10^{-12}$  and  $-6 \times 10^{-12}$ , are used to find the output resistance of RTD with respect to various values of  $R_0, a, b$  and  $c$ . These output resistance are used as inputs of data conversion circuit output voltage is generated. The MATLAB environment is used for simulating.

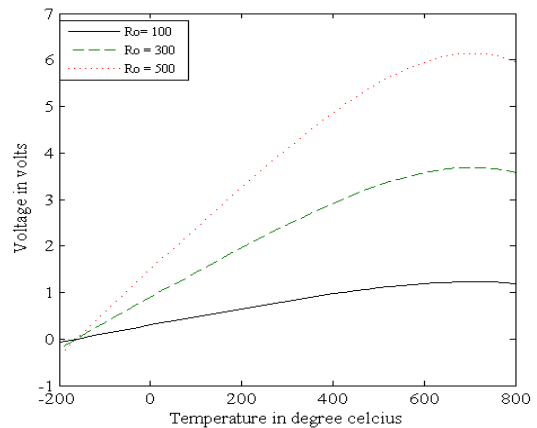

Fig.3. Output voltage for variation of temperature and  $R_0$ , for  $a = 2 \times 10^{-3}, b = -5 \times 10^{-7}$  and  $c = -2 \times 10^{-12}$

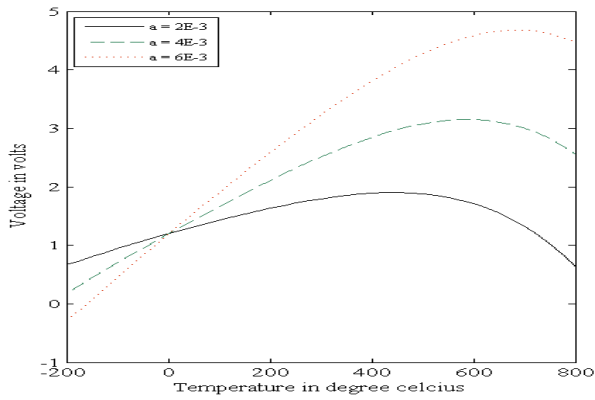

Fig.4. Output voltage for variation of temperature and a, for  $R_o = 300$ ,  $b = -5 \times 10^{-7}$  and  $c = -2 \times 10^{-12}$

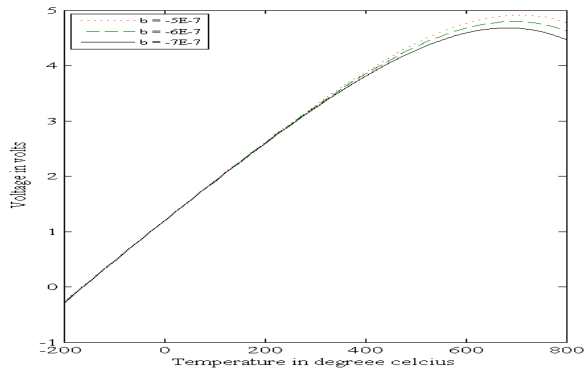

Fig.5. Output voltage for variation of temperature and b, for  $R_o = 100$ ,  $a = 4 \times 10^{-3}$  and  $c = -2 \times 10^{-12}$

Fig 3, Fig 4 and Fig 5 shows the variation of voltage with the change in input temperature considering different values of  $R_o$ , a, b and c.

It has been observed from the above graphs that the relation between input temperature and voltage output of data conversion unit has a non linear relation. Datasheet of RTD suggests that the input range of 5% to 70% of full scale is used in practice as linear range. These are the reasons which have made the user to go for calibration techniques using some circuits. Further, the output voltage also varies with the change in  $R_o$ , a, b and c. These conventional calibration techniques have drawbacks that its time consuming and need to be calibrated every time when RTD is changed in the system. Further, the use is restricted, to a portion of full scale for linearity.

To overcome these drawbacks, this paper makes an attempt to design a temperature measuring technique incorporating intelligence to produce linear output and to make the system independent of physical parameters like  $R_o$ , a, b and c using the concept of artificial neural network.

## V. PROBLEM SOLUTION

The drawbacks discussed in the earlier section are overcome by adding an optimal ANN model in cascade with data converter unit. This model is designed using the neural network toolbox of MATLAB.

The first step in developing a neural network is to create a database to train, validate and test the network. Output voltages of the system for the change in temperature,  $R_o$ , a, b and c form the input matrix; target matrix would be the expected linear response of RTD as shown in Fig 6.

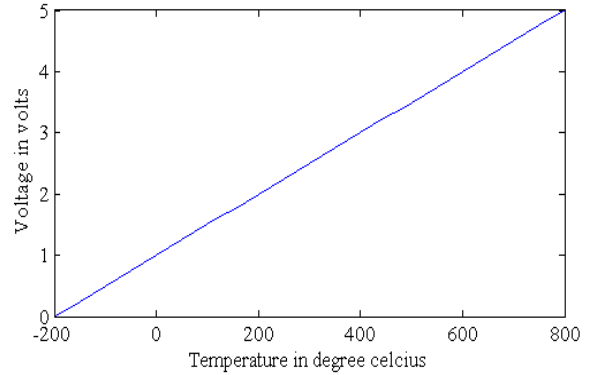

Fig.6. Target graph

The functionality of ANN can be explained as given below. First the data is initialized; like training base (60%), test base (20%), validation base (20%), number of layers and neurons, type of the transfer functions, number of iteration and estimate error threshold. The network is trained to compute the weights. Once the weights are computed, it is verified to have mean square error (MSE) is less than estimate error threshold (Th) for at least 10 consecutive readings. If the above condition is satisfied the whole model is saved, else the iteration for updates of ANN parameters continue till it reaches the maximum number of iteration and then the model is saved with caution that desired performance has not reached. Else the system will accept a new set of data to satisfy the conditions. Mean Squared Error (MSE) is the average squared difference between outputs and targets. Lower value of MSE is better. Zero MSE means no error. Regression R measures the correlation between outputs and targets. Value of R is 1 means a close relationship and 0 means a random relationship.

### A. OPTIMAL ANN

Initially, only one hidden layer is chosen and assuming a particular scheme and an algorithm training, validation and testing is completed. The result is shown in Table 1. If the values of R and MSE are not close to the expected values, number of hidden layers is increased by one more and training, validation and testing is done again. This continues till acceptable values of R and MSE are achieved. Thus,



optimal number of hidden layer is found corresponding to a scheme and an algorithm. This process is repeated with Gauss-newton Algorithm (GNA) [17] and [18], Levenberg-marquardt algorithm (LMA) [17] and [19], Back Propagation neural network (BP) trained by Ant Colony Optimization (ACO) [20-22] and Radial Basis Function (RBF) trained by ACO [23-25] and results are shown in table-1. Results in table.1 reveals that RBF scheme with ACO algorithm gives accurate result even using only one hidden layer. But for higher accuracy two numbers of hidden layers are used. Fig 7 shows the structure of the neural network considered in the present case using RBF trained by ACO algorithm.

Table 1. Comparison of number of hidden layer with R and MSE

NHL	SA/PM	GNA	LMA	BP trained by ACO	RBF trained by ACO
1	MSE	4.56E-3	1.25E-3	1.11E-4	3.65E-5
	R	0.83992	0.88999	0.9924	0.9995
2	MSE	7.79E-5	5.36E-5	3.25E-6	7.89E-8
	R	0.9965	0.99514	0.99875	0.99996
3	MSE	6.32E-8	8.54E-9	1.32E-9	7.38E-10
	R	0.99998	0.99994	0.99999	0.999999
4	MSE	8.2E-10	2.5E-11	9.93E-11	
	R	0.999991	0.999992	0.999999	

NHL – Number of hidden layers;  
 SA – Scheme and algorithm;  
 PM – Performance measure;

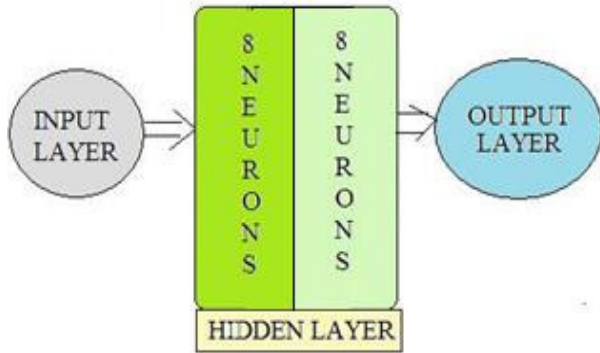

Fig.7. Structure of neural network model

With the details mentioned the network is trained, validated and tested. Table 2 summarizes the various parameters of the measured network model.

Table 2. Summarizes the network model

OPTIMIZED PARAMETERS OF THE NEURAL NETWORKS MODEL		
Database	Training base	102
	Validation base	34
	Test base	34
No of neurons in	1st layer	8
	2nd layer	8

Transfer function of	1st layer		logsig			
	2nd layer		logsig			
	Output layer		linear			
Input	Temp	R <sub>o</sub>	a	b	c	
	min	-200 °C	100	2x10 <sup>-3</sup>	-5x10 <sup>-7</sup>	-2x10 <sup>-12</sup>
	max	800 °C	500	6x10 <sup>-3</sup>	-7x10 <sup>-7</sup>	-6x10 <sup>-12</sup>

## VI. Result and Conclusions

The proposed ANN is trained, validated and tested with the simulated data. Once the training is over, for the system with RTD along with other modules in cascade as shown in Fig 1, it is subjected to various test inputs corresponding to different physical parameters like R<sub>o</sub>, a, b and c all within the specified range. For testing purposes, the range of temperature is considered from -200 °C to 800 °C, range of R<sub>o</sub> is 100 to 500, range of a is 2x10<sup>-3</sup> to 6x10<sup>-3</sup>, range of b is -5x10<sup>-7</sup> to -7 x10<sup>-7</sup>, range of c is -2x10<sup>-12</sup> to -6x10<sup>-12</sup>. The input output result is plotted and is shown in Fig 8. The output graph is matching the target graph as shown in Fig 6.

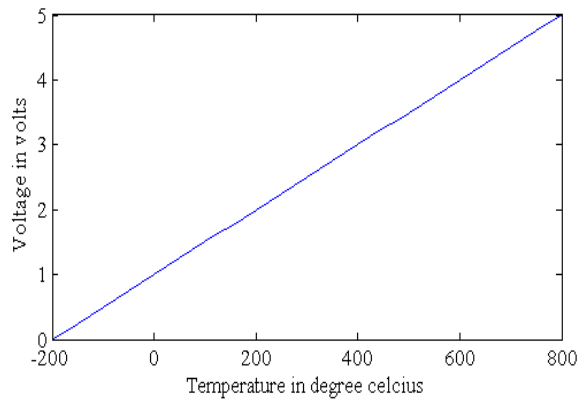

Fig. 8. Response of proposed system for real inputs

It is evident from Fig 8, that the proposed measuring technique discussed has incorporated intelligence to the RTD by increasing the linearity range of the RTD. Also, the output is made independent of physical parameters like R<sub>o</sub>, a, b and c. Thus, if the RTD is replaced by another RTD of different physical parameters the system does not require any calibration to give the accurate reading. All these have been achieved by using an optimal ANN.

In [5], [6], [7], [8], [9], [10], mainly the extension of linear range is discussed. The proposed work is a clear significant improvement over the existing reported works. The proposed work not only solves the task of extension of linear range but also makes the system output independent of physical parameters of RTD like R<sub>o</sub>, a, b and c. In [11], linearization of RTD and making the output independent of physical parameters are discussed. This proposed work is an improvement over [11] by using linear data conversion circuit.

Further, the algorithm is optimized to produce accurate results with less number of hidden layers compared to [11]

## References

- [1] M Attari, "Methods For Linearization of Non-Linear Sensors", Proc. CMMNI-4, Fourth Maghrebin Conference on Numerical Methods of Engineering, Algiers (Algeria), Vol. 1, pp.344-350, Nov.1993.
- [2] J A. Freeman, Neural Networks: Algorithms, Applications, and Programming Techniques, Addison-Wesley, Massachusetts, 1992.
- [3] M.E. Aggoune, F. Boudjema, A. Bensenouci, A Hellal, S.V. Vadari, M.R. El Mesai, "Design of an adaptive-structure voltage regulator using artificial neural networks", Proc. of the 2nd IEEE Conference on Control Applications, Vancouver, Canada, September 1993.
- [4] L.F. Pau and F.S. Johansen, "Neural Network Signal Understanding for Instrumentation", IEEE Transactions on instrumentation & Measurement, Vol.39, No.4, Aug. 1990, pp.558-564.
- [5] N.Hambali, S.Saat, M.A. Ahmad, M.S.Ramli, M.A.Ishak, " Computer-based System for Temperature Measurement Calibration of RTD", 3rd International Conference on Information Management, Innovation Management and Industrial Engineering,, Kunming, China, 2010
- [6] Najidah Hambali, Shahrizal Saat, Mohd Syakirin Ramli, Mustaqim Hazmi, "Automatic Detection Computer-based System for Temperature Measurement Calibration of RTD", Proc. International Conference on Electrical, Control and Computer Engineering, Phang, Malaysia, June 2011.
- [7] Edval J P Santos, Isabela B Vasconcelos, "RTD-based Smart Temperature Sensor: Process Development and Circuit Design", Proc. 26<sup>th</sup> International Conference on Microelectronics, Serbia, May 2008.
- [8] Shakeb A. Khan, D.T. Shahani, A.K. Agarwala, "Sensor calibration and compensation using artificial neural network", ISA Transactions, vol 42, Issue 3, pp. 337-352, 2003.
- [9] Application note: AN105, Dataforth Cooperation, Tuscon, 2008.
- [10] Bonnie C. Baker, Precision Temperature Sensing With RTD Circuits – AN687, Microchip Technology Inc. 2008.
- [11] Santhosh K V, B K Roy, "An Intelligent Temperature Measuring Technique Using RTD" National Conference on Advanced Control in engineering systems (NACES 11), Bangalore, India, September 2011.
- [12] Santhosh K V, B K Roy, "A Smart Temperature Measuring Technique Using Thermistor", International Journal of Engineering Science and Management, Vol I, No 2, pp 62-68, 2011.
- [13] Bela G Liptak, Instrument Engineers Handbook-Process Measurement and Analysis, 4<sup>th</sup> Edition, CRC Press, 2003.
- [14] John P Bentley, *Principle of Measurement Systems*, 3<sup>rd</sup> Edition, Pearson Education Publication, India, 2003.
- [15] Saibal Pradham, Susanta Sen, "An Improved Lead Compensation Technique for Three Wire Resistance Temperature Detectors, Journal IEEE Transactions on Instrumentation and Measurement, vol 48, No. 5, pp. 903-905, 1999.
- [16] Omega Complete Temperature Measurement Handbook and Encyclopedia.Stamford, CT: Omega, vol. 26, p. T-21, 1988.
- [17] Björck A, *Numerical methods for least squares problems*, SIAM Publications, Philadelphia. ISBN 0-89871-360-9, 1996.
- [18] Fletcher, Roger, *Practical methods of optimization*, 2<sup>nd</sup> Edition, John Wiley & Sons, New York. ISBN 978-0-471-91547-8, 1987.
- [19] Fernando Morgado Dias, Ana Antunes1, José Vieira, Alexandre Manuel Mota, Implementing The Levenberg-Marquardt Algorithm On-line: a sliding window approach with early stopping. *Int. Conf. Proc. IFAC*, USA, 2004.
- [20] Jeng-Bin Li, Yun-Kung Chung, A Novel Back propagation Neural Network Training Algorithm Designed by an Ant Colony Optimization, *IEEE/PES Transmission and Distribution Conference & Exhibition: Asia and Pacific Dalian, China 2005*
- [21] L. Bianchi, L.M. Gambardella, M.Dorigo, An ant colony optimization approach to the probabilistic travelling salesman problem, *Proc. of PPSN-VII, Seventh Inter17 national Conference on Parallel Problem Solving from Nature*, Springer Verlag, Berlin, Germany, 2002
- [22] Stuart Russell and Peter Norvig, Artificial Intelligence A Modern Approach, 3<sup>rd</sup> Edition, Prentice Hall New York, 2009.
- [23] Park J, Sandberg J W, Universal Approach Using Radial Basis Function Network, *Neural Computation*, Vol 3, pp. 246-257, 1991
- [24] T Poggio, F Girosi, "Networks for approximation and learning," Proc. IEEE 78(9), pp. 1484-1487, 1990.
- [25] Paul Yee V and Simon Haykin, Regularized Radial Basis Function Networks: Theory and Applications, John Wiley, 2001.