

# DTMF operated robot for space operation with applications

Jasleen Josan<sup>1</sup>

**Abstract**— Dual-tone Multi-frequency (DTMF) Signals are used in touch-tone telephones as well as many other areas. Since analog devices are rapidly changing with digital devices, digital DTMF decoders become important. In this survey a brief review of some DTMF detector implementations is given. The Aim of this paper is to implement a DTMF detector, which is ITU complaint, on a fixed point low cost DSP. This detector should be able to detect DTMF tones in multiple-channels with as much as possible channels. Microcontrollers, as the name suggests, are small controllers. They are also used in automobiles, washing machines, microwave ovens, toys .etc. where automation is needed.

**Keywords**— DTMF, PWM, Path finder, Radio control , multi-frequency.

## I. TECHNOLOGY USED

### A. Dual-Tone Multi-Frequency (DTMF)

Dual-tone multi-frequency (DTMF) signaling is used for telecommunication signaling over analog telephone lines in the voice-frequency band between telephone handset sand other communications devices and the switching center. The version of DTMF used for telephone tone dialing is known by the trademarked term Touch-Tone.

### B. Telephone Keypad

The contemporary keypad is laid out in a 3×4grid, although the original DTMF keypad had an additional column for four now-defunct menu selector keys. The row in which the key appears determines the low frequency, and the column determines the high frequency. For example, pressing the '1' key will result in a sound composed of both a 697 and a 1209 hertz (Hz) tone. The original keypads had levers inside, so each button activated two contacts. The Multiple tones are the reason for calling the system multi frequency. These tones are then decoded by the switching center to determine which key was pressed.



A DTMF Telephone Keypad

DTMF Keypad Frequencies (With Sound Clips):

	1209 Hz	1336 Hz	1477Hz	1633 Hz
697 Hz	1	2	3	A
770 Hz	6	7	8	B
852 Hz	7	8	9	C
941 Hz	*	0	#	D

DTMF Event Frequencies :

Event	Low freq.	High freq.
-------	-----------	------------

Busy signal	480 Hz	620 Hz
Dial Tone	350 Hz	440Hz
Ringback Tone(US)	440Hz	480Hz

### C. Tones#, \*,A,B,C and D

The engineers had envisioned phones being used to access computers, and surveyed a number of companies to see what they would need for this role. This led to the addition of the number sign (#, sometimes called 'octothorpe' in this context) and asterisk or "star" (\*) keys as well as a group of keys for menu selection: A, B, C and D. In the end, the lettered keys were dropped from most phones, and it was many years before these keys became widely used for vertical service codes such as \*67 in the United States and Canada to suppress caller ID.

The U.S. military also used the letters, relabeled, in their now defunct Autovon phone system. Here they were used before dialing the phone in order to give some calls priority, cutting in over existing calls if need be.. The levels of priority available were Flash Override (A), Flash (B), Immediate (C), and Priority (D), with Flash Override being the highest priority.

### D. Backgrounds

A DTMF signal consists of two superimposed sinusoidal waveforms whose frequencies are chosen from a set of eight standardized frequencies. For example, by pressing the '1' button from the touch-tone telephone key pad, a signal made by adding a 697 Hz and a 1209 Hz sinusoid are generated.

Detecting multi-frequency signals in noisy environments is a well-studied area in DSP.

The difficulty of DTMF tone detection is due to the standards which must be satisfied when 3\ detecting these signals. For example, the standard frequencies are determined in AT&T Bell The ITU specification is as follows:

1) Signal frequencies:

Low group (Hz): 697, 770, 852, 941

High group (Hz): 1209, 1336, 1477, 1633

2) ITU frequency tolerances:

a. Maximum accepted frequency offset is 1.5%

b. Minimum rejected frequency offset is 3.5%

3) Signal Reception Timing:

a. Minimum accepted tone duration is 23 ms,

b. Maximum rejected tone duration is 40 ms,

c. Minimum pause time between two tones is 40 ms,

d. Allowable interrupt within a tone is 10 ms,

4) Twist (power difference between frequencies)

### E. Present Work

I worked on the DTMF OPERATED ROBOT project which was based on embedded technology which is the combination of three programs. We can call it three in one which is made by using (line + object + DTMF).

- Line Follower
- Object (path finder)
- DTMF



## II. LINE FOLLOWER:

Project Line Following Autonomous Robot is based on 8 bit Microcontroller AT89C2051. This Robot follows the black line which is drawn over the white surface or it follows the white line which is drawn over the black surface. The infrared sensors are used to sense the line. When the infrared signal falls on the white surface, it gets reflected and if it falls on the black surface, it is not reflected this principle is used to scan the Lines for the Robot.

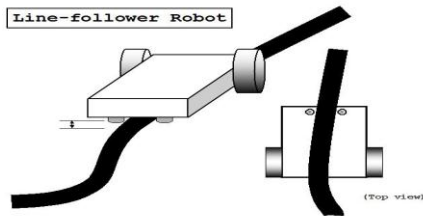

This simple robot is designed to be able to follow a black line on the ground without getting off the line too much. The robot has two sensors installed underneath the front part of the body, and two DC motors drive wheels moving forward.

### A. Theory of operation

#### a) How to sense a black line

The sensors used for the project are Reflective Object Sensors, OPB710F that are already ready in the Electronic Lab. The single sensor consists of an infrared emitting diode and a NPN Darlington phototransistor. When a light emitted from the diode is reflected off an object and back into the phototransistor, output current is produced, depending on the amount of infrared light, which triggers the base current of the phototransistor.

How to control a DC motor

### B. Circuit diagram

My circuit consists of two parts: PWM (Pulse Width Modulation) part and a sensor part. First, we take a look at the sensor part. The photodiode turns on the phototransistor and then the output current is converted to output voltage through the first op-amp circuit. The R6 is a variable resistor, so that we can tune the scale of output voltage. The second op-amp circuit is added to change the polarity of voltage. (Positive CV is necessary later.) One thing we should know is that -Vcc to Vcc of voltage rail is needed, not from 0 to Vcc. In the circuit built-up, LM747 Dual Operational Amplifiers were used.

Second, in the PWM section, two 555 timers (LM555) are used to produce a pulse-width modulated train of pulses. The timer on the left works in as table mode to generate regular square-wave pulses. The frequency is fixed by the values of R1, R2 and C1 here. Then, this output Q1 is connected to the trigger pin of the second timer that works in monostable mode this time. As you can see in the diagram, at a falling edge of Q1, a pulse is triggered and stays high during some time. The time (width of a pulse) is purely determined by the value of R3 and C3 if CV (Control Voltage) pin is not connected at all. (Look at the pulse diagrams of Q1 and Q2 at the bottom of the circuit diagram.) CV plays a role of changing the threshold level of a timer. (Without CV, threshold =  $2/3 * V_{cc}$ ) CV just becomes the triggering voltage level. In my robot, the distance between sensors and the ground is fixed. When a sensor is off the black line, CV keeps its maximum value and both motors turning in constant speed. As soon as the sensor enters the black line part, CV drops down and thus duty cycle decreases, which means the slowdown of a wheel.

\* Component Values:

R1=6K, R2=1K, R3=20K, R4=10, R5=82, R6=5K(variable), R7=1K  
 C1=1μF, C2=0.1μF, C3=0.1μF

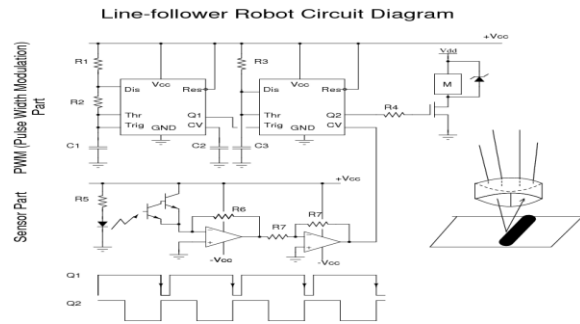

### C. Building Robot

Before starting to build a real circuit, I built is on the lab breadboard and verified everything worked fine. Then, I bought a blank breadboard from ECE storeroom. I put together each electronic part and wires on the board and soldered them all. (The work would have been much easier to use a PCB (Printed Circuit Board).) After that, I checked if there is any bad connection, and tested if the circuit generates correct pulses at each point. (i.e. Q1 and Q2) This whole work took quite a time, much longer than I expected. For a robot body, I bought a container and two flying wheel toys at the Wal-Mart. With every part ready, I drilled holes to fix two DC motors, some supporting aluminum plates and sensors in front.

### D. Result

For a test, I held my robot in the air and I approached a white paper to sensors.. I found the torque of motors not enough to drive my robot. Overall, the robot project wasn't successful, but it was quite a fun to go through all the process. I also realized that there were many things to consider practically such as installation of motors, building up a circuit by soldering and putting all parts together. This experience hopefully would be helpful in the future work. Some snapshots of my robot are on the next page.

### E. Block diagram



As shown in the above block diagram first block is the Cell Phone. So, it acts as a DTMF generator with tone depending up on key pressed. So ultimately the two motors rotate according to the key pressed on the keypad on the cell phone.

### F. Components used

#### 1) Resistors

VALUE	QUANTITY
56K	4
150K	1
10K	6
47K	1
68K	1
330K	1

2) Capacitors

COMPONENT	QUANTITY
6V,200RPM DC MOTOR	2
RESET SWITCH	1
9V DC BATTERY	2
CONNECTING WIRES	-

3)Oscillators

VALUE	QUANTITY
0.1microF	3
22microF	4
10microF	1

3) Miscellaneous

VALUE	QUANTITY
3.57MHz	1
1.2MHz	1

4) Circuit Diagram

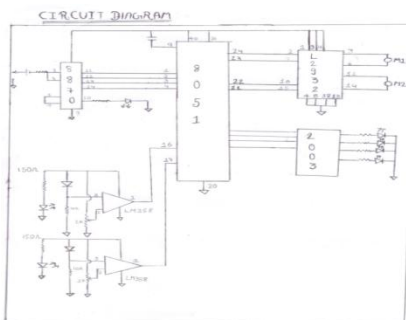

G. Problems faced

Although the concept & design of the project seemed perfect, there were some problems faced while actual implementation:

1. Connecting Hands free of cell phone to DTMF decoder IC input:

There were several types of Hands Free cords available in the market, the right one had to be chosen from them. Several ways to break up the cords and connect them to the input of IC 8870 were tried & some were newly developed by us (e.g. Connecting Audio Jack of PC's speakers to the cell phone with help of an extender).

Solution:

Finally Hands Free cord's 'Earplugs' were removed & resulting set of wires were connected in an appropriate manner to the Decoder IC's input.

2. Selection of Mobile Phone:

At first, latest cell phone like Nokia 5700, N-series were tried. But they couldn't give any output. Several cell phones were tested with their respective Hans free cords.

Solution:

The older version phones like Nokia 1100, Nokia 2300 were found to be more suitable for the purpose. Finally Nokia 2690 was used.

H. Final design layout

PCB LAYOUT:

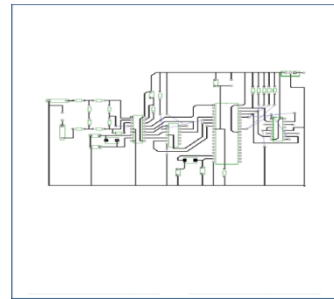

ACTUAL PCB PHOTOGRAPH  
SIDE VIEW:



E.Circuit description

The important components of this robot are a DTMF decoder, microcontroller and motor driver.

A CM8870 series DTMF decoder is used here. All types of the CM8870 series use digital counting techniques to detect and decode all the 16 DTMF tone pairs into a 4-bit code output. The built-in dial tone rejection circuit eliminates the need of pre-filtering.

When the input signals are given at pins 1(IN+) & 2(IN-), a differential input configuration is recognized to be effective, the correct 4-bit decode signal of the DTMF tone is transferred to (pin11) through (pin14) outputs. The pin11 to pin14 of DTMF decoder are connected to the pins of microcontroller (P1.4 to P1.7).

I. Program Code

```
#include<reg51.h>
#include<string.h>
#define dtmf P1
#define ldata P0
sbit rs=P3^0;
sbit rw=P3^1;
sbit e=P3^2;
sbit motor1_a=P2^0;
sbit motor1_b=P2^1;
sbit motor2_a=P2^2;
sbit motor2_b=P2^3;
sbit sen=P3^7;
sbit sen1=P3^6;

void motor_run();
void motor_stop();
void turn_left();
void turn_right();
void backward();
void lcd_data(unsigned char);
void lcd_cmd();
void delay();

void delay_l0();
void lcdstring(unsigned char *);
void cmd(unsigned char value);
```

```

void main()
{
    dtmf=0x0f;
    sen=1;
    sen1=1;
    lcd_cmd();
    lcdstring("three in one...");
    delay();

    for(;;)
    {
        if(dtmf==0x03)
        {
            lcd_cmd();
            lcdstring("path finder");
            delay();
            if(sen==0)
                motor_run();
            if(sen==1)
            {
                motor_stop();
                delay_l();
                backward();
                delay_l();
                turn_right();
                delay_l();
            }
        }

        if(dtmf==0x07)
        {
            lcd_cmd();
            lcdstring("line follower");
            delay();
            if(sen==1&&sen1==1)
            {
                motor_run();
            }
            if(sen1==0&&sen==1)
            {
                turn_right();
            }

            if(sen1==1&&sen==0)
            {
                turn_left();
            }
            if(sen==0&&sen1==0)
            {
                backward();
            }
        }

        if(dtmf==0x06)
        {
            turn_right();
        }

        if(dtmf==0x05)
        {
            motor_stop();
        }
        if(dtmf==0x04)
        {
            turn_left();
        }
        if(dtmf==0x02)
        {
            motor_run();
        }
        if(dtmf==0x08)
        {
            backward();
        }
    }
}

void motor_run()
{
    motor1_a=1;
    motor1_b=0;
    motor2_a=1;
    motor2_b=0;
}

void motor_stop()
{
    motor1_a=0;
    motor1_b=0;
    motor2_a=0;
    motor2_b=0;
}

void turn_left()
{
    motor1_a=1;
    motor1_b=0;
    motor2_a=0;
    motor2_b=0;
}

void turn_right()
{
    motor1_a=0;
    motor1_b=0;
    motor2_a=1;
    motor2_b=0;
}

void backward()
{
    motor1_a=0;
    motor1_b=1;
    motor2_a=0;
    motor2_b=1;
}

void lcd_cmd()
{
    char i;
    char c[5]={0x38,0x01,0x0E,0x06,0x80};

    for(i=0;i<5;i++)
    {

```

```

        cmd(c[i]);
        delay();
    }
}

void cmd(unsigned char value)
{
    ldata=value;
    rs=0;
    rw=0;
    e=1;
    delay();
    e=0;
}

void lcd_data(unsigned char value)
{
    ldata=value;
    rs=1;
    rw=0;
    e=1;
    delay();
    e=0;
}

void lcd_string(unsigned char *p)
{
    while(*p!='\0')
    {
        Lcd_data(*p);
        delay();
        p++;
    }
}

void delay_1()
{
    int i,j;
    for(i=0;i<15000;i++)
        for(j=0;j<10;j++);
}

void delay()
{
    int i;
    for(i=0;i<8000;i++);
}
    
```

## J. Software used

### a) Dip trace

Role in design :

Dip Trace 1.50 proved to be a very handy & easy-to-use tool for the PCB layout process. Many of its features were utilized leading to an accurate & efficient design. It has Design Error Check & Electrical Rule Check tools which proved to be helpful in the design. It is loaded with a huge component list that is categorized in various libraries for giving simplicity. Placement of components is also very easy & they can be rotated in 360° to customize the design.

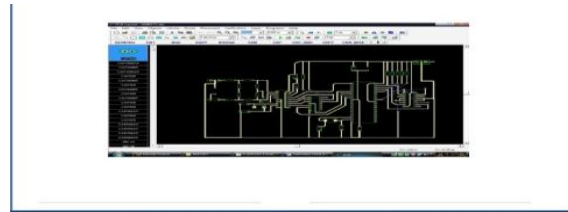

## K. Applications

*Scientific:* Remote control vehicles have various scientific uses including hazardous environments, working in the Deep Ocean, and space exploration. The Voyager I spacecraft is the first craft of any kind to leave the solar system.

*Military and Law Enforcement:* Military usage of remotely controlled military vehicles dates back to the first half of 20th century.. Remote control vehicles are used in law enforcement and military engagements for some of the same reasons. The exposure to hazards is mitigated to the person who operates the vehicle from a location of relative safety. Remote controlled vehicles are used by many police department bomb-squads to defuse or detonate explosives. See Dragon Runner, Military robot. Unmanned Aerial Vehicles (UAVs) have undergone a dramatic evolution in capability in the past decade. Early UAV's were capable of reconnaissance missions alone and then only with a limited range. Current UAV's can hover around possible targets until they are positively identified before releasing their payload of weaponry.

*Search and Recues:*

UAVs will likely play an increased role in search and rescue in the United States. Slowly other European countries (even some developing nations) are thinking about making use of these vehicles in case of natural calamities & emergencies. This can be a great asset to save lives of both people along with soldiers in case of terrorist attacks like the one happened in 26 Nov, 2008 in Mumbai, India. The loss of military personnel can be largely reduced by using these advanced methods.

This was demonstrated by the successful use of UAVs during the 2008 hurricanes that struck Louisiana and Texas.

Conclusion

Controlling devices using switches are common. From few decades controlling devices using remote control switches like infrared remote control switch, wireless remote control switches, light activated switches are becoming popular. But these technologies have their own limitations. Laser beams are harmful to mankind. Some technologies like IR remote control are used for short distance applications. In such case if we have system which does not require any radiations or which is not harmful, long remote control switch.

Here I am introducing such a system which does not require any radiations, any laser beam which has no limitations of range; it can be used from any distance using a simple mobile phone. The robot is totally controlled by a mobile phone. It operated through the keypads of the mobile phone. It can move left, right forward and reverse also.

### III. FUTURE IMPROVEMENTS & FUTURE SCOPE

#### 1. *IR Sensors:*

IR sensors can be used to automatically detect & avoid obstacles if the robot goes beyond line of sight. This avoids damage to the vehicle if we are maneuvering it from a distant place.

#### 2. *Password Protect*

Project can be modified in order to password protect the robot so that it can be operated only if correct password is entered. Either cell phone should be password protected or necessary modification should be made in the assembly language code.

#### 3. *Alarm Phone Dialer:*

By replacing DTMF Decoder IC CM8870 by a 'DTMF Transceiver IC' CM8880, DTMF tones can be generated from the robot. So, a project called 'Alarm Phone Dialer' can be built which will generate necessary alarms for something that is desired to be monitored (usually by triggering a relay).

#### 4. *Adding a Camera:*

If the current project is interfaced with a camera (e.g. a Webcam) robot can be driven beyond line-of-sight & range becomes practically unlimited as GSM networks have a very large range.

Jasleen Josan<sup>1</sup> is with the Sathyabama University of Science and Technology, Jeppiaar Nagar, Rajiv Gandhi Salai, Chennai 600119 INDIA

(+919176173050).

#### REFERENCES

- [1] M.A. Mazidi & THE 8051 MICROCONTROLLER, AYALA "DTMF TESTER" Electronics for You, Edition July (2011)
- [2] WEB REFERENCES:
- [3] Wikipedia-The free encyclopedia
- [4] <http://www.8051projects.info/>
- [5] <http://www.alldatasheet.com>
- [6] <http://www.electronicstest.com/>
- [7] <http://www.google.com/>
- [8] <http://www.electrofriends.com/>
- [9] G. O. Young, "Synthetic structure of industrial plastics (Book style with paper title and editor)," in *Plastics*, 2nd ed. vol. 3, J. Peters, Ed. New York: McGraw-Hill, 1964, pp. 15-64.