

Liquid cooling system in a personal hybrid computing system based on graphics processors

[Daulet Akhmedov, Suleimen Yelubayev, Farida Abdoldina, Timur Bopeyev, Daulet Muratov]

Abstract — Article presents a structural scheme of a personal hybrid computer system (PHCS) based on graphics processors with liquid cooling system. Here are presented the results of experiments to determine the effectiveness of the liquid cooling system. Results of measurements the level of acoustic noise from PHCS, temperature of heating the PHCS components in case of using the system of air and liquid cooling in normal mode and at maximum load are presented in this paper.

Keywords—parallel computing, high-performance computing, hybrid computing system, GPU accelerator, CUDA technology, air cooling system, liquid cooling system.

I. Introduction

The problem of cooling computer components becomes more acute every year. Processors and GPU accelerators power are increases, and with it power consumption increasing and proportionally increases the heat dissipation capacity, which can reach 130-225 watts today. Manufacturers of central and graphics processors adopt new, more subtle technological process in order to keep processors heat generation, but it still not enough.

CPU and GPU modern cooling system is characterized by the performance and the level of acoustic noise. For personal computers its size is limited to 50 dBA, and for workstations and servers - 70 dBA. Using of personal computer is comfortable when the noise of cooling system is minimal.

The main advantage of the liquid cooling system, as compared to aerogenic cooling system is considerably large performance and a low noise level. Liquid cooling system has high performance because the thermal conductivity of the fluid in the five - to seven times higher than that of air, respectively, is less than its thermal resistance and higher heat flux. Another feature of the liquid cooling system is that the temperature of the cooled object is changed relatively slowly, due to the thermal inertia of the liquid [1].

II. Personal hybrid computing system with liquid cooling system

Personal hybrid computing system based on graphics processors ISTT HPC 2000 (Figure 1) was developed at the Institute of Space Equipment and Technology [2].

D. Akhmedov, S. Yelubayev, F. Abdoldina, T. Bopeyev, D. Muratov
The Institute of Space Technique and Technologies
Republic of Kazakhstan

Generally personal hybrid computer system is a high-performance personal computer, which may be located directly at the workplace of the user. The composition of personal hybrid computing system generally coincides with the composition of the personal computer, except that it includes specialized high-performance graphics processors Nvidia Tesla, actually realizing quick calculations. Powerful CPU and several GPU together form high-performance computing system, where intensive tasks can be shared between the processors, thereby providing a high parallelism and computational speed.

PHCS configuration includes the following components: two CPUs Intel Xeon E5-2690 2.9Ghz; motherboard Asus Z9PE-D8 WS; four GPUs Nvidia Tesla K20c; eight modules of RAM DDR3 16Gb 1600MHz.

The real performance of personal hybrid computing system based on four GPU Nvidia Tesla K20c in the Linpack test was 3353 gigaflops (3.4 teraflops) of double precision; it is 71.65% of peak performance.



Figure 1. Dependence Personal hybrid computing system based on graphics processors

In designing a hybrid personal computer system main difficulty is the calculation of scheme of powerful CPU and GPU optimum ratio, cooling system, optimal power scheme.

To provide necessary cooling level with heavy use of graphics processors it have been developed two variants of PHCS cooling system.

In the first variant an effective air-cooling system has been developed, constructed in such a way that air flow can freely circulate between the computing nodes of personal computing system, preventing them from overheating. For this purpose it was applied the most efficient mechanical elements of cooling system - fans with low level of noise emissions as well, as a special type of system block case, allowing to some extent arbitrarily change the location of the cooling devices.

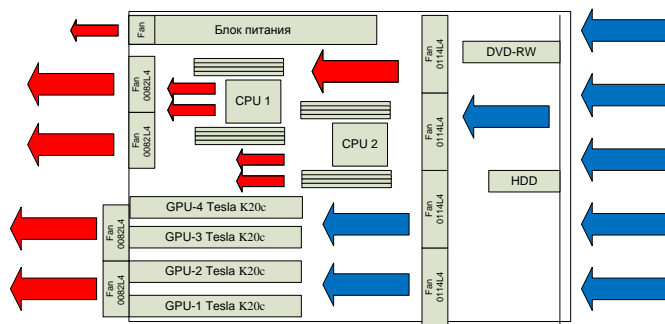
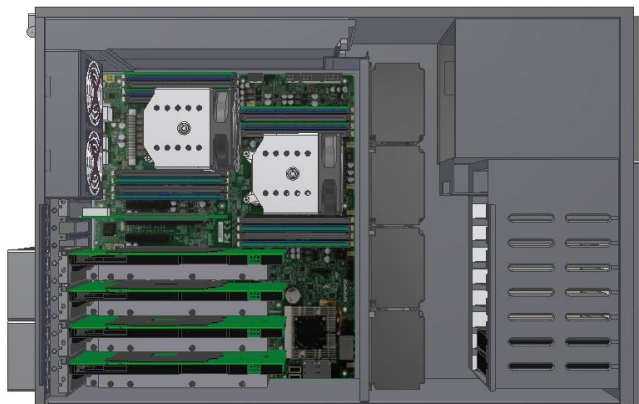

Figure 2. PHCS system block case cooling scheme

There are 4 pumping and 4 exhaust axial fans in the PHCS system block. Fans flow characteristics, sufficient to remove the heat generated by the elements of PHCS is calculated according to the procedure described in [3]. Figure 2 shows a scheme of the cooling system of PHCS system block case based on three GPUs.

Figure 3 shows 3D model of PHCS with air cooling system.



a) side view, without side wall



b) back view

Figure 3. 3D model of PHCS with air cooling system

Due to the fact that personal hybrid computing system can be used both in educational institutions and in permanent jobs, according to the established norms of the noise intensity, the maximum value of the noise generated by the computer system shall not exceed 50 dB.

In the second variant it has been developed an effective liquid cooling system. Figure 4 shows a structural scheme of PHCS based on four GPUs with liquid cooling system.

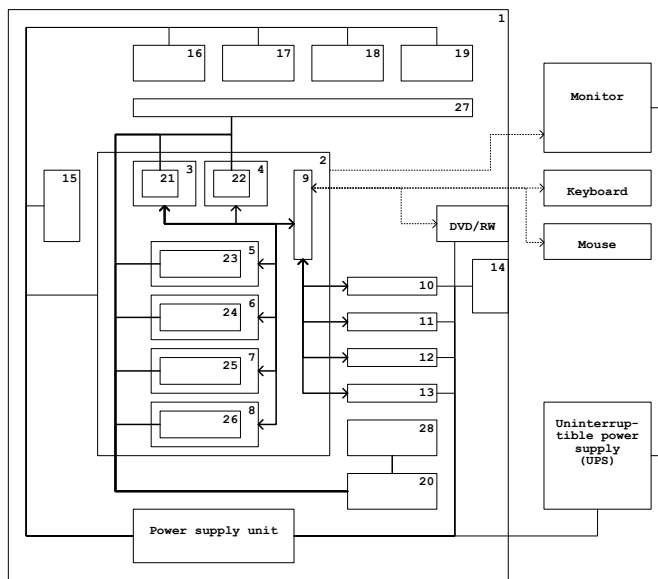

Figure 4. Structural scheme of a personal hybrid computer system with liquid cooling

The following is a description of the purpose of components placed inside the case of personal hybrid computing system based on graphics processors.

Component 1 - case. Size and structure of the case allow to locate the required amount of graphics processors and provide sufficient cooling level.

Component 2 - motherboard. Provides linking and control other devices, allow to accommodate a sufficient number of graphics processors to achieve high-performance systems.

Components 3-4 - CPUs with a clock frequency of 2.9 GHz, are managing all system components, have 40 lines PCI-Express, which allows the most use of the resources of GPUs.

Components 5-8 - graphics processors with peak performance of 1.17/3.52 teraflops of single and double precision, respectively, carry out high-performance computing.

Component 9 - random access memory with capacity of 128GB, is designed for temporary storage of processed data. High total amount of RAM allow reducing the number of references to the hard drives, thereby increasing productivity of system.

Components 10-13 - hard drives up to 1TB each, designed for long-term storage. Number of hard drives may differ depending on the requirements for the minimum amount of stored data.

Component 14 - blowing fan with a diameter 120 mm, provides cold air flows blowing into the case to the hot components of the system.

Component 15 - back exhaust fan with a diameter 120 mm, ensures the removal of hot air flows from the central processors.

Components 16-19 - top exhaust fans with a diameter 120 mm, provide output of hot air out of the system.

Component 20 - pump that provides forced circulation of the fluid in the liquid cooling system.

Components 21-22 - water blocks of CPUs, designed to remove heat from the central processor and its transmission to working fluid.

Components 23-26 - GPU water blocks, designed to remove heat from the GPU and its transfer to working fluid.

Component 27 - radiator, designed to dissipate the heat of the working fluid in the loop of liquid cooling system.

Component 28 - working fluid reservoir, provide compensation of thermal expansion of the liquid, increase the thermal inertia of the liquid cooling system and the convenience of filling and draining the working fluid.

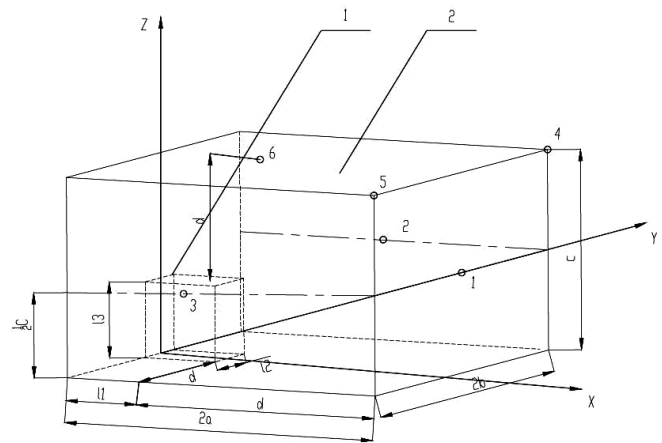

Figure 5. Supporting parallelepiped.
 1- reference parallelepiped, 2 - measuring surface

III. The results of experiments

Noise emission measuring.

To determine the corrected sound power level it is used technical method for determining the corrected sound power level in free field over a reflecting plane according to State Standard 12.1.026-80 «Occupational safety standards system. Noise. Determination the noise characteristics of noise sources in the free field over a reflecting plane. Technical method» or method to determining the corrected sound power level in the reverberant room according to State Standard 12.1.027-80 «Occupational safety standards system. Noise. Determination of the noise characteristics of noise sources in reverberant room. Technical method». These methods allow to get the values of sound power levels with the maximum values of the standard deviation of sound power levels in accordance with State Standard 23941-79 «Noise. Methods for determination noise characteristics. General requirements». Requirements for the placement of personal hybrid computing system during the noise measurement: PHCS devices of floor type installed in the operation against the wall, would be located on a reflecting floor in front of a reflecting wall at a distance of 0.1 m from the wall. During measurements of PHCS device mode is installed in accordance with appendix 3 of State Standard 26329-84 «Computing machines and data processing system. Permissible noise levels of technical means and methods of their determination». Prior to testing, the device operated a sufficient time necessary to ensure a steady temperature.

Supporting parallelepiped was used as the measurement surface for personal hybrid cooling system. Its faces are located at a distance of measurements from them, equal to 1 m. Data from these measurements of sound power are shown in Table 1. Number of measuring point corresponds to the measuring point of supporting parallelepiped shown in Figure 5.

TABLE I. THE RESULTS OF MEASUREMENTS OF SOUND POWER OF PERSONAL COMPUTING HYBRID SYSTEM

Measuring point number	PHSC with air cooling system		PHSC with liquid cooling system	
	In idle, Db	Under load, Db	In idle, Db	Under load, Db
1	50,4	65,4	48,2	50,3
2	50,3	64,6	52,4	54,7
3	51,4	64,4	49,2	51,6
4	50,7	62,3	52,6	50,2
5	50,5	62,6	48,9	51,5
6	52,1	64,2	49,9	52,7

The measurements of personal hybrid computing system sound power conducted during normal operation mode and maximum processors load. Experiments were conducted for PHCS with two variants of cooling system: air and liquid cooling system.

Analyzing the results we see that when using liquid cooling system at maximum processor load noise level is reduced by an average of 20%, which is 12 dB. When hybrid personal computing system work in normal mode, there isn't significant changes (Figure 6).

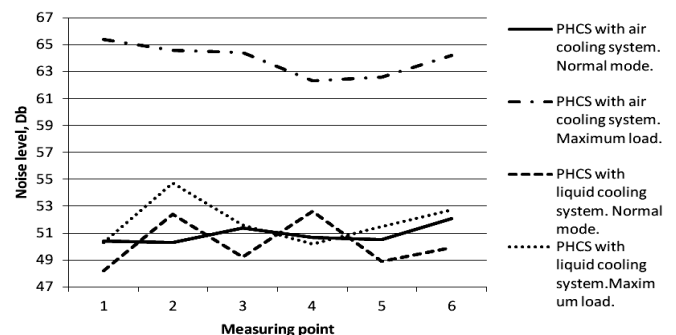

Figure 6. The results of measurements of sound power of personal hybrid computing system

Measurements of PHCS main components heating temperature also conducted in two modes: normal mode and at maximum load processors. Analyzing the results of temperature measurement shown in Table 2 and Figure 7, we see that the GPU heating temperature with a maximum load is

reduced by almost twice, average by 46% and in normal mode by 30%. At the same time, the results of cooling for CPUs and motherboard do not have advantages that makes to think about the further improvement of the liquid cooling system.

TABLE II. THE RESULTS OF MEASUREMENTS OF PERSONAL HYBRID COMPUTING SYSTEM HEATING COMPONENTS

Component	PHSC with air cooling system		PHSC with liquid cooling system	
	Temperature at maximum load, C	The temperature in the normal operation mode, C	Temperature at maximum load, C	The temperature in the normal operation mode, C
CPU 1	83	47	87	48
CPU 2	74	41	74	41
GPU 1	81	42	46	30
GPU 2	84	42	46	30
GPU 3	83	42	44	30
GPU 4	84	42	44	29
System temperature (Motherboard)	59	34	64	37

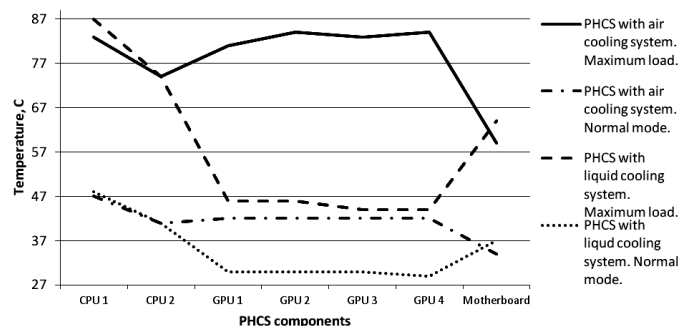

Figure 7. The results of measurements of personal hybrid computing system heating components

IV. Conclusion

The obtained results of measuring of personal hybrid computing system sound power showed a noise reduction when using liquid cooling system by 20% and reduction of operating temperature of GPUs almost twice, it proves that the liquid cooling system in a hybrid personal computing system is more efficient than air cooling system.

Reducing the level of noise even at maximum load of personal hybrid computing system with liquid cooling system to the requirements of a personal computer, makes the work with personal hybrid computing system comfortable and allows to place a high-performance computing system near the work area.

Efficient cooling of GPU reduces the probability of overheating and affects the lifetime beneficially.

References

[1] Kandyrin U.V. Choice of devices for cooling of processors in electronic equipment [Vybor ustrojstv ohlazhdenija processorov v jelektronnoj apparature] / U.V. Kandyrin, S.A. Hvastynets. Ejournal

"Sistemotekhnika" N4 edition of MIEM Moscow. 2006. [Electronic resource]. URL: www.systech.miem.edu.ru/ogl-4. (in Russian)

[2] Akhmedov D., Yelubayev S., Abdoldina F., Bopayev T., Muratov D., Povetkin R., Karataev A. "Personal hybrid computing system. Performance test" \ Collection of scientific papers Second International conference "Cluster Computing 2013", -Lvov, June 3-5, -2013., -pp. 7-11.

[3] Sorokin A. Diagrams of switching on the fans for cooling of system units of personal computers [Shemy vkljuchenija ventiljatorov dlja ohlazhdenija sistemnyh blokov personal'nyh komp'yuterov]. Part 1.: [Electronic resource]. URL: www.electrosad.ru (in Russian)

About Author (s):



Daulet Sh. Akhmedov
 Doctor of technical science,
 Director of
 AALR "Institute of space technique
 and technology"



Suleimen A. Yelubayev
 Head of laboratory of space systems
 simulation, AALR "Institute of space
 technique and technology"



Farida N. Abdoldina
 candidate of technical science
 Leading researcher of laboratory of
 space systems simulation, AALR
 "Institute of space technique and
 technology"

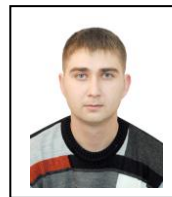

Timur M. Bopayev
 Senior scientist of laboratory of space
 systems simulation, AALR "Institute
 of space technique and technology"



Daulet M. Muratov
 Leading software engineer of
 laboratory of space systems
 simulation, AALR "Institute of space
 technique and technology"